

FUJIFILM
Value from Innovation

FUJIFILM

<https://global.fujifilm.com/>



CROSS-OVER CAPABILITIES

FDR CROSS **NEW**

*External appearance and specifications are subject to change without notice. *All brand names or trademarks are the property of their respective owners.
*All products require the regulatory approval of the importing country. *For details on their availability, contact our local representative.
*Please contact FUJIFILM's authorized distributor for FDR Cross system.

FUJIFILM Corporation
26-30, NISHIAZABU 2-CHOME, MINATO-KU, TOKYO 106-8620, JAPAN
<https://global.fujifilm.com/>

Ref. No. XB-1073E (SK-22-02-F1079-F9711) Printed in Japan ©2022 FUJIFILM Corporation



Fluoroscopy. Still images. One smart fluoroscopy cart. **FDR CROSS**

Fluoroscopy (video) and still images with one device.

The FDR CROSS C arm provides a single solution for Fluoroscopic imaging and static X-ray image acquisition. Its unique tilting tube head and removable detector design, provide significantly greater freedom of imaging and efficiency compared to conventional configurations of a separate C arm and mobile X-ray machine.

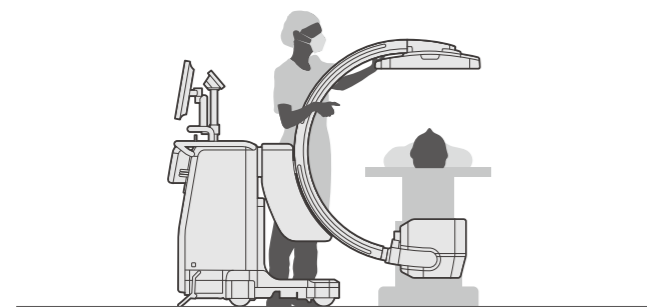

Fluoroscopy mode

Use as a C-arm digital fluoroscopy system during surgery. Up to 17"×17" FOV fluoroscopy mode.

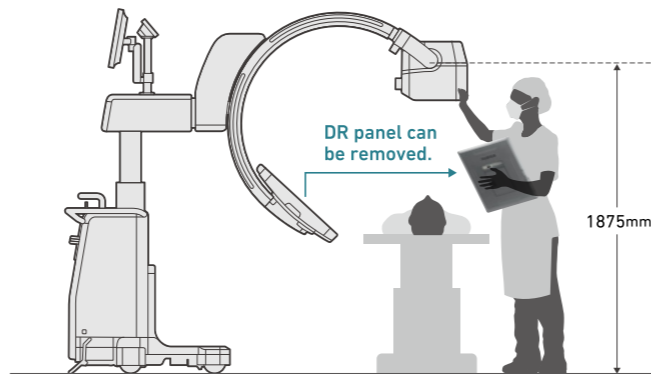

Radiography mode

For static x-ray image acquisition before, during and after surgery, the DR panel can be removed from the panel holder (separate DR panel can also be used).

Switch between three panel sizes for the same device

The panel holder of the detector can be detached and DR panels in three sizes* can be used. Switch between different panel sizes to perform a wide range of surgical examinations and procedures.



10" × 12"
(25 × 30 cm)

14" × 17"
(35 × 43 cm)

17" × 17"
(43 × 43 cm)

*FDR D-EVO III (brand name: DR-ID1800 Digital Radiography Device) only. Fluoroscopy mode can only be used for products in the FDR D-EVO III C series.

Uses for each area

Choose different panel sizes to suit each area of the body — use the easy-to-rotate 10"×12" size for limbs and the wide angle 14"×17" or 17"×17" size for the spine and hip joints.



Limb (10"×12")



Spine and hip joints (14"×17")

Uses for each purpose

Use the small 10"×12" panel during surgeries, where imagining is more localized. Before and after surgeries, you can use the larger 17"×17" panel to take images across a wider area.



Fluoroscopy during a surgery (10"×12")

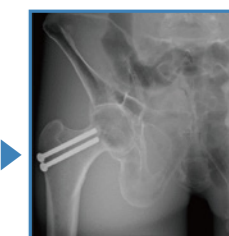

Still image after a surgery (17"×17")

Lightweight, compact, space-saving design

The compact, lightweight FDR CROSS weighs only 249 kg giving superior mobility in a busy operating room. Its integrated design and a C arm aperture of 83 cm provides improved imaging and user experience.



*when using the 10" x 12" panel



Superior mobility and user-friendly controls to reduce stress

Light, smooth sideways movement and turning

Omni wheels at the front provide smooth all round movements when positioning in small spaces. Dual side mounted brake pedals and wrap around handles enable smooth and secure control when moving and stopping. This superior mobility is extremely helpful in operating rooms where equipment position constantly changes from procedure to procedure.

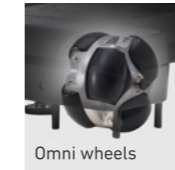

No need to plug into a power source

The built-in quick-charge lithium battery provides power for eight hours* of continuous use when fully charged, enabling a cable free workflow. A power cable can be connected when the battery is low or extended use is required.



*Depends on usage conditions

Cable free operation for greater safety and convenience

Wireless connection to the optional foot switch and monitor cart, removes the need for cable management and risk in the operating room. The monitor cart supports wireless HDMI, enabling two screens to be displayed with no lag.



Easy-to-use control panels

Control panels for the arm are located on both sides — operate the arm and magnetic lock from any position.

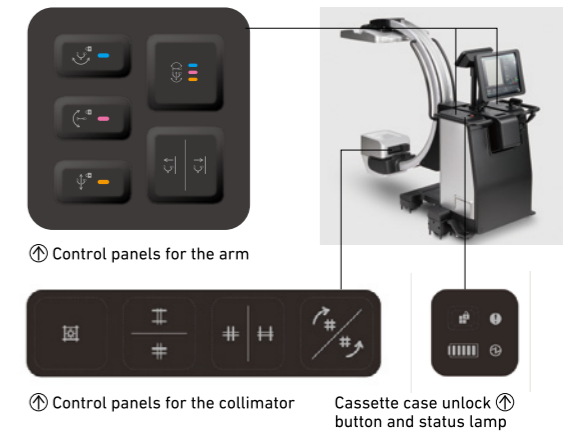

Integrated cable

The high-voltage cable is incorporated into the arm, allowing uncluttered movement and improved cleaning.



Antibacterial finish to maintain cleanliness **Hydro Ag**

The control panel and hand switches where there is frequent contact are coated with Fujifilm's antibacterial Hydro Ag coating.

Free adjustment of C-arm height

The C-arm can be moved up and down easily. Moving down the X-ray focal spot to less than 1m helps to operate easily for lateral imaging.

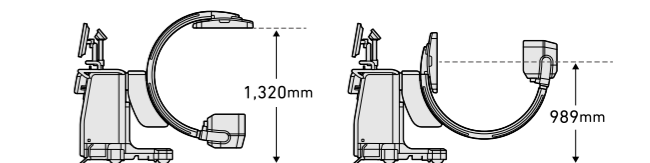

Manage information efficiently by connecting to a network

DICOM connectivity provides the transfer of patient and examination information to RIS/PACS, including Dose SR enabling dose management information to be saved.





High quality imaging for surgical and medical procedures

Integrated console for Fluoroscopy and X-ray images

FDR CROSS uses a single console for both Fluoroscopy and X-ray images. In fluoroscopy mode, snapshots and last image hold (LIH) captures can be used as reference images in the two-screen display. In Radiography mode, X-ray imaging can be performed for a complete imaging workflow.

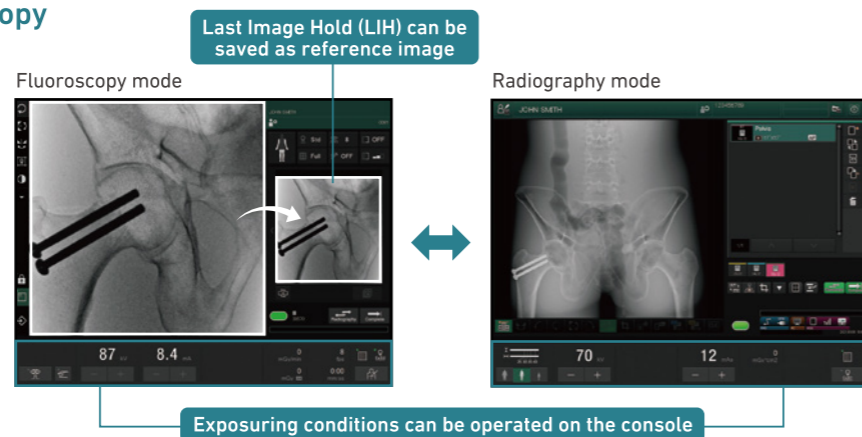

Fujifilm's technology performs image processing frame by frame, enabling clearer images to be generated with a lower dose and less image lag.

Dynamic core engine

Dynamic processing and noise reduction is performed frame by frame. These conditions enable clear images with less image lag.



Dynamic Visualization II

Differing thicknesses in areas of the body and nearby structures are recognized from converted 3D information, and the contrast and density are adjusted.

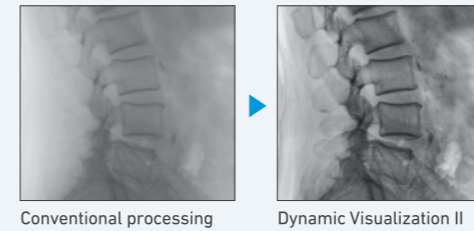

Noise reduction processing

Unstructured noise components are extracted and reduced to improve the granularity of the image. This enables greater visibility of the subject structure.

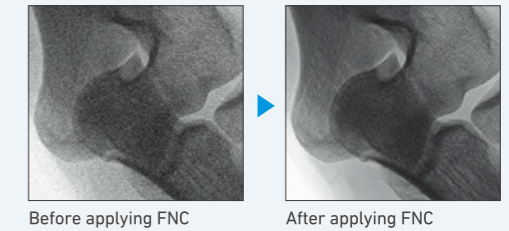

Dose reduction by image processing

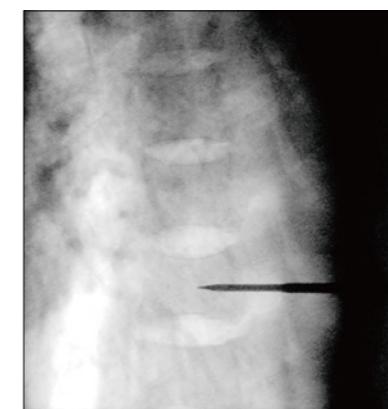

General processing
Dose: 8.4mA

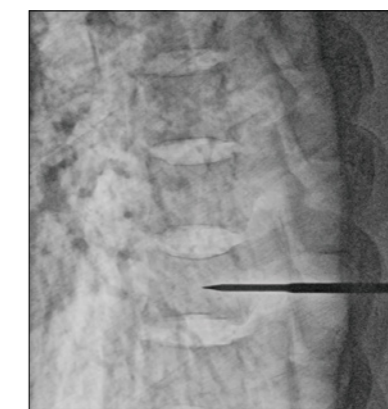

After applying Dynamic processing
Dose: 8.4mA

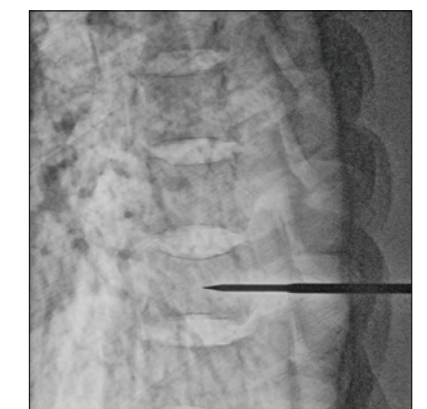

After applying Dynamic processing + noise reduction
Dose: 4.2mA

Synergism between ISS method and flexible film-based detector (FUJIFILM FDR D-EVO III)

The indirect-conversion FPD uses the ISS method, where the light sensor (TFT sensor) is attached to the irradiation side, the opposite side to that used for a conventional FPD. This coupled with a flexible film sensor TFT panel instead of the traditional glass TFT provides significantly reduced scattering/ reduction of X-ray signals, in turn producing sharp images with low X-ray dose. A DQE of 58% (1 Lp/mm, 1 mR) is achieved. (C series only).

The advantages of using film

X-ray transmittance is improved by using thin film for the TFT panel instead of glass. This helps to achieve high resolution images with low X-ray dosage. Fujifilm's proprietary ISS method makes it possible further the advantages of flexible sensors.

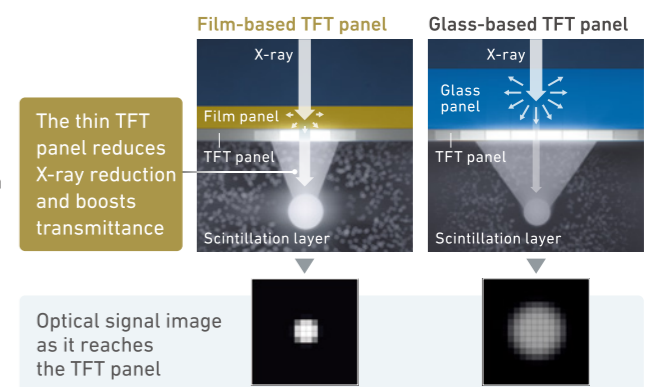

FDR D-EVO III Series

We have a wide range of cassette FPDs, with benefits such as a lightweight, waterproof and dustproof design, high load tolerance and resistance to impact such as falling. Modern FPD's that stand up to the challenges of an operating room.

